

Stop Valves Series 1500 3600 PSI @ 100°F (248.3 BAR @ 38°C)

These Series 1500 valves are designed and rated to Flowserve Edward Valve standards. See 3.2 Pressure Ratings in the Technical Information section for additional information.

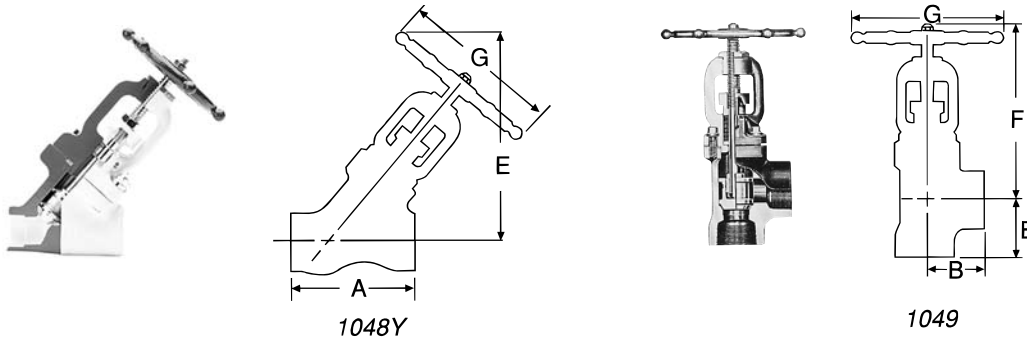

Standard Features

- Bodies and bonnets are of forged steel (A105 or F11).
- Bolted bonnet, OS & Y.
- Y-Pattern or angle design.
- Body-guided hardened stainless steel disk.
- Integral Stellite seat.
- Integral backseat.
- 13% chromium stainless steel stem.
- Asbestos-free graphitic packing.
- Asbestos-free spiral wound bonnet gasket.
- Knobbed handwheel.

Series 1500

FIG. NO.	TYPE	ENDS	NPS (DN)
1048	Y-Pattern	Threaded	¼ (6) thru 2 (50)
1048Y	Y-Pattern	Socket Welding	
1049	Angle	Threaded	
1049Y	Angle	Socket Welding	

Dimensions - Globe & Angle

Black numerals are in inches and pounds
Colored numerals are in millimeters and kilograms

Figure No. 1048/1048Y, 1049/1049Y	NPS	¼	3/8	½	¾	1	1¼	1½	2
	DN	8	10	15	20	25	32	40	50
A - End to End, Globe		3	3	3	3.6	4.3	5.8	5.8	6.5
		76	76	76	91	109	147	147	165
B - Center to End, Angle		1.5	1.5	1.5	1.8	2	2.9	2.9	3.3
		38	38	38	46	51	74	74	84
E - Center to Top, Globe (Open)		6.1	6.1	6.1	6.9	7.6	10.9	10.9	12.1
		155	155	155	175	197	277	277	307
F - Center to Top, Angle (Open)		5.8	5.8	5.8	6.6	7.1	10.2	10.2	11
		147	147	147	168	183	259	259	279
G - Handwheel Diameter		3.8	3.8	3.8	4.3	4.8	7.1	7.1	8.5
		97	97	97	109	122	183	183	216
Weight, Globe		4	4	4	5.5	8	17	17	24
		1.8	1.8	1.8	2.5	3.6	7.7	7.7	10.8
Weight, Angle		4	4	4	5.5	7.5	17	17	25
		1.8	1.8	1.8	2.5	3.4	7.7	7.7	11.3